

ROAD MAINTENANCE EQUIPMENTS

INDEX

STANDARD SNOW BLADE	PAG. 64
HEAVY DUTY SNOW BLADE	PAG. 66
TILT DOZER BLADE	PAG. 68
EXTENSION ARM	PAG. 69
SWEEPER BUCKET	PAG. 70
ANGLE ROLL SWEEPER	PAG. 72
UNIVERSAL SWEEPER	PAG. 74

STANDARD SNOW BLADE

Snow blade applicable on skid loaders, mini wheel loaders and agricultural tractors. Hydraulic shock proof system, hydraulic angle $\pm 30^\circ$, self-leveling system to the road surface of $\pm 10^\circ$, anti-shock system with spring return, feet support and hydraulic connections.

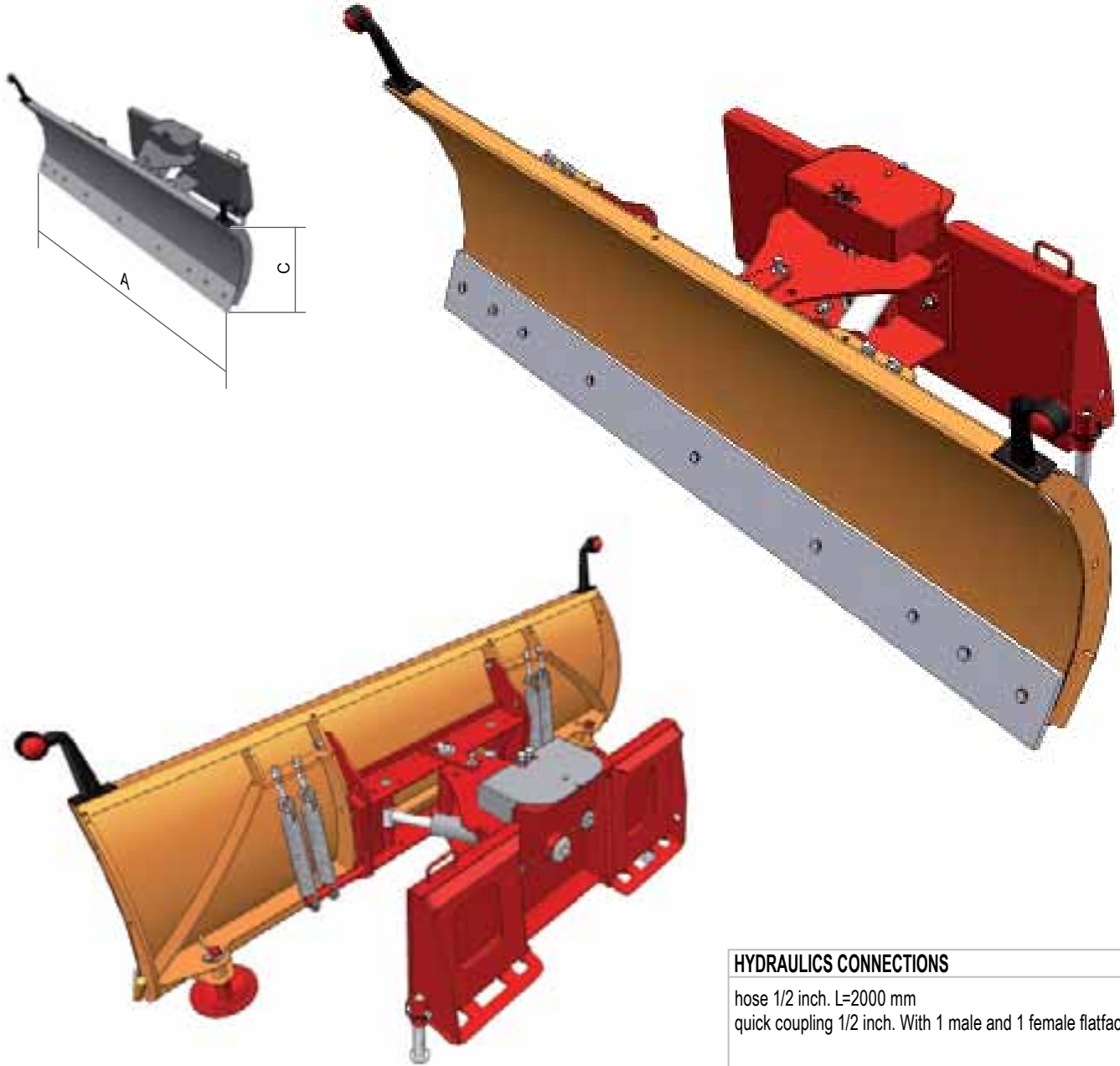

HYDRAULICS CONNECTIONS
 hose 1/2 inch. L=2000 mm
 quick coupling 1/2 inch. With 1 male and 1 female flatface

STANDARD EQUIPMENTS

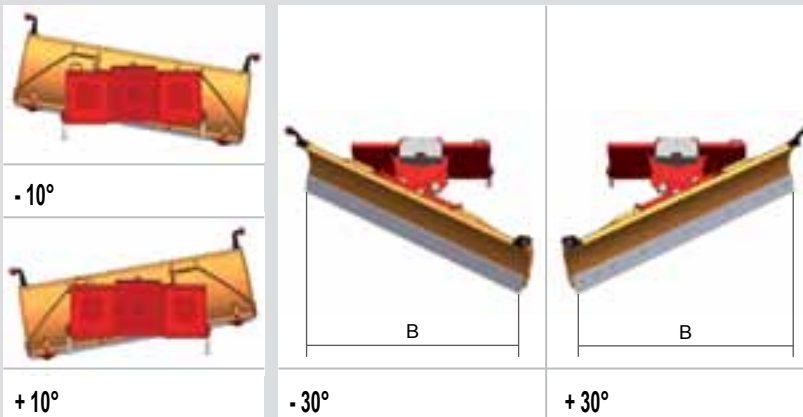

OPTIONAL

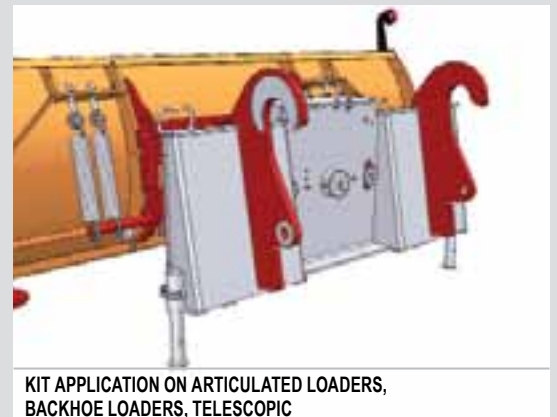

KIT APPLICATION ON ARTICULATED LOADERS,
 BACKHOE LOADERS, TELESCOPIC

TECHNICAL SPECIFICATION

WEIGHT MACHINE	ton	the matching will be advise according to the technical details of the machine				
MODEL		LN 1300	LN 1600	LN 1850	LN 2100	LN 2500
A	mm	1305	1605	1855	2105	2505
B (width blade on 30°)	mm	1125	1385	1605	1820	2165
C	mm	740	740	740	740	740
WEIGHT		285	300	315	330	355
MAX PRESSURE	bar	180	180	180	180	180

USE DETAIL



OPTIONAL



CROWDED LIGHTS

OPTIONAL

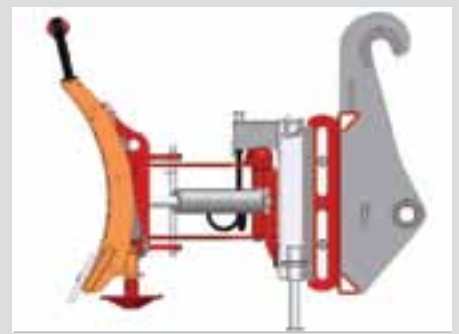

COMPACT MECHANIC FLOATING

OPTIONAL

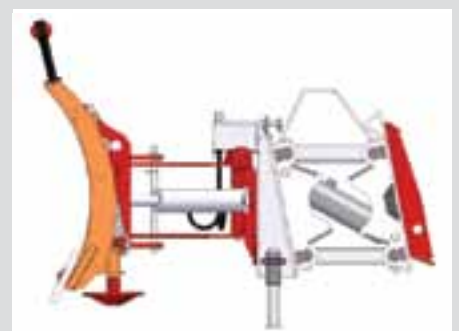

FLOATING WITH HYDRAULIC CILINDER

OPTIONAL



LATERAL RUBBER EARS

OPTIONAL



TOP SUPPORT

MODEL	
LN 1300	
LN 1600	
LN 1850	
LN 2100	
LN 2500	

OPTIONAL



RUBBER BLADE

MODEL	
LN 1300	
LN 1600	
LN 1850	
LN 2100	
LN 2500	

HEAVY DUTY SNOW BLADE

Snow blade applicable on tracked skid loaders, wheel loaders, backhoe loaders, telescopic and agricultural tractors. Hydraulic shock proof system, hydraulic angle $+ / - 30^\circ$, self-leveling system to the road surface of $+ / - 10^\circ$, anti-shock system with spring return, feet support and hydraulic connections.

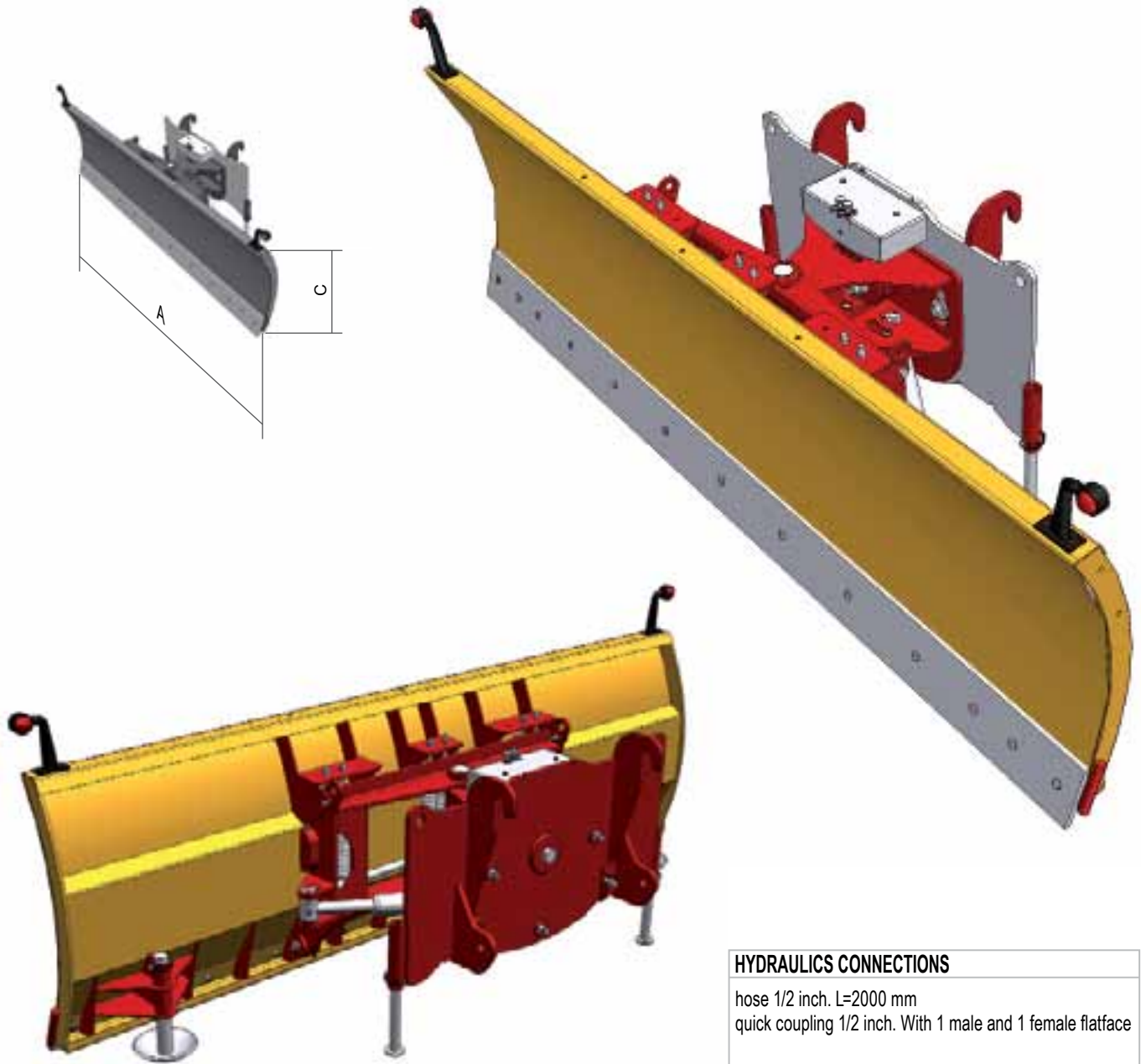

HYDRAULICS CONNECTIONS
 hose 1/2 inch. L=2000 mm
 quick coupling 1/2 inch. With 1 male and 1 female flatface

STANDARD EQUIPMENTS

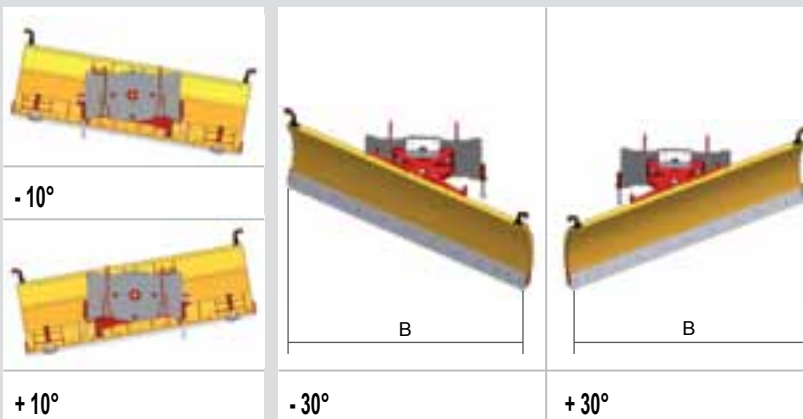

OPTIONAL

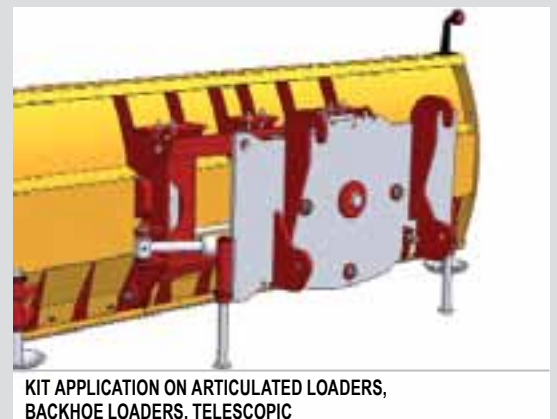

KIT APPLICATION ON ARTICULATED LOADERS, BACKHOE LOADERS, TELESCOPIC

TECHNICAL SPECIFICATION

WEIGHT MACHINE	ton	the matching will be advise according to the technical details of the machine			
MODEL		LN 2500 HD	LN 2700 HD	LN 2900 HD	LN 3100 HD
A	mm	2505	2705	2905	3105
B (width blade on 30°)	mm	2165	2345	2510	2690
C	mm	1000	1000	1000	1000
WEIGHT		645	660	675	690
MAX PRESSURE	bar	180	180	180	180

USE DETAIL



OPTIONAL



CROWDED LIGHTS

OPTIONAL



COMPACT MECHANIC FLOATING

OPTIONAL



FLOATING WITH HYDRAULIC CILINDER

OPTIONAL

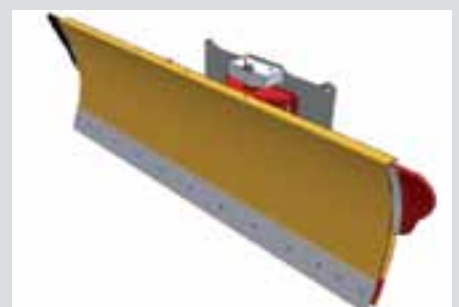

LATERAL RUBBER EARS

OPTIONAL



TOP SUPPORT

MODEL	
LN 2500 HD	
LN 2700 HD	
LN 2900 HD	
LN 3100 HD	

OPTIONAL

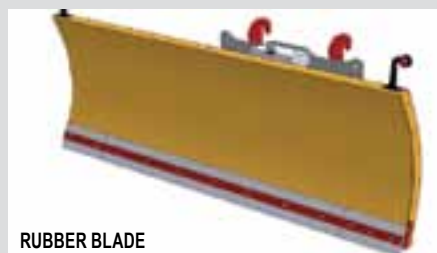

RUBBER BLADE

MODEL	
LN 2500 HD	
LN 2700 HD	
LN 2900 HD	
LN 3100 HD	

TILT DOZER BLADE

Dozer Blade applicable on skid loaders, mini wheel loaders, telescopic and agricultural tractors. Hydraulic angle $\pm 30^\circ$, hydraulic horizontal leveling $\pm 8^\circ$, double acting hydraulic solenoid valve, and depth adjustment sleigh. Blade is made of anti wear material HB400.

HYDRAULICS CONNECTIONS

hose 1/2 inch. L=2000 mm
quick coupling 1/2 inch. With 1 male and 1 female flatface

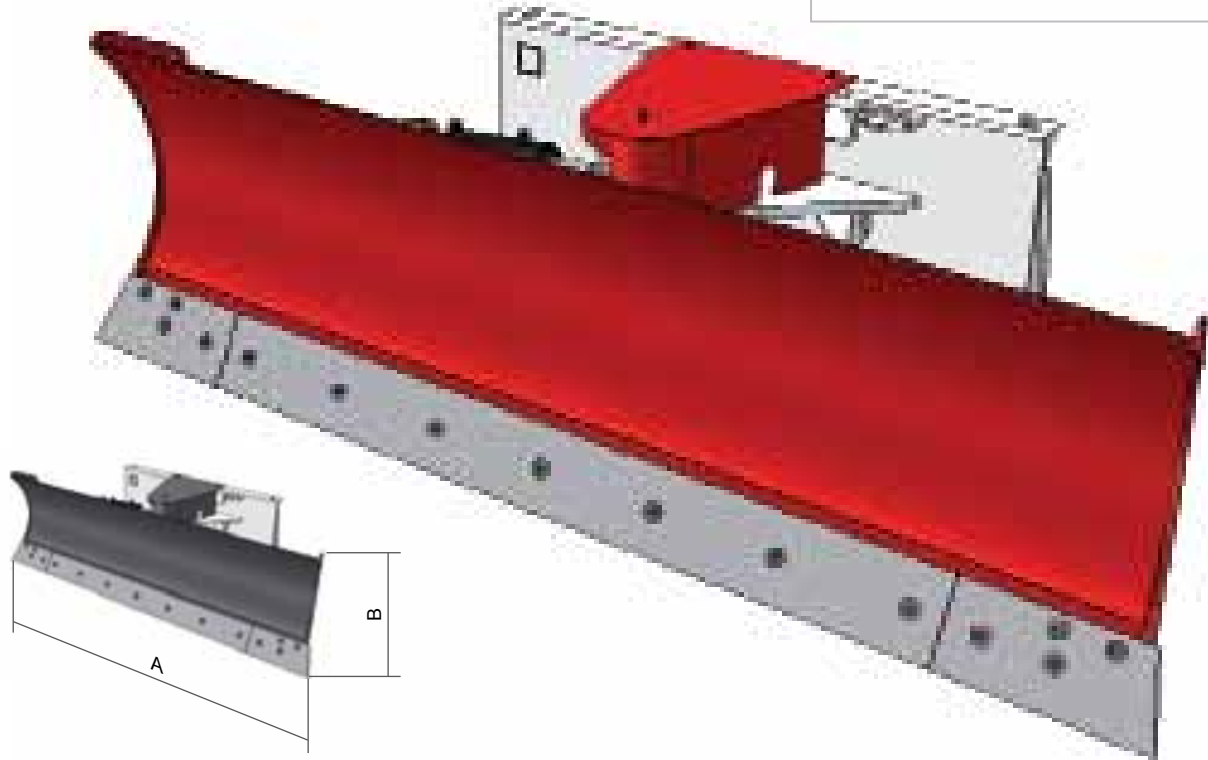

TECHNICAL SPECIFICATION

WEIGHT MACHINE	ton	the matching will be advise according to the technical details of the machine		
MODEL		LBD 230	LBD 250	LBD 280
A	mm	2300	2500	2800
B	mm	640	640	640
WEIGHT	kg	420	460	500
WIDTH AT 30°		2000	2170	2420
MAX PRESSURE	bar	200	200	200

OPTIONAL



KIT APPLICATION ON ARTICULATED LOADERS,
BACKHOE LOADERS, TELESCOPIC

STANDARD EQUIPMENTS

- HORIZONTAL SELFLEVELING $\pm 8^\circ$
- HYDRAULIC ANGLE $\pm 30^\circ$
- HYDRAULIC SYSTEM WITH ELECTRO DISTRIBUTOR DOUBLE EFFECT
- DEPTH REGULATION SLIDES

DETAIL LEVELLING



EXTENSION ARM

Applicable for mini/midi excavators, it can extend work field. Particularly indicated for drains cleaning.

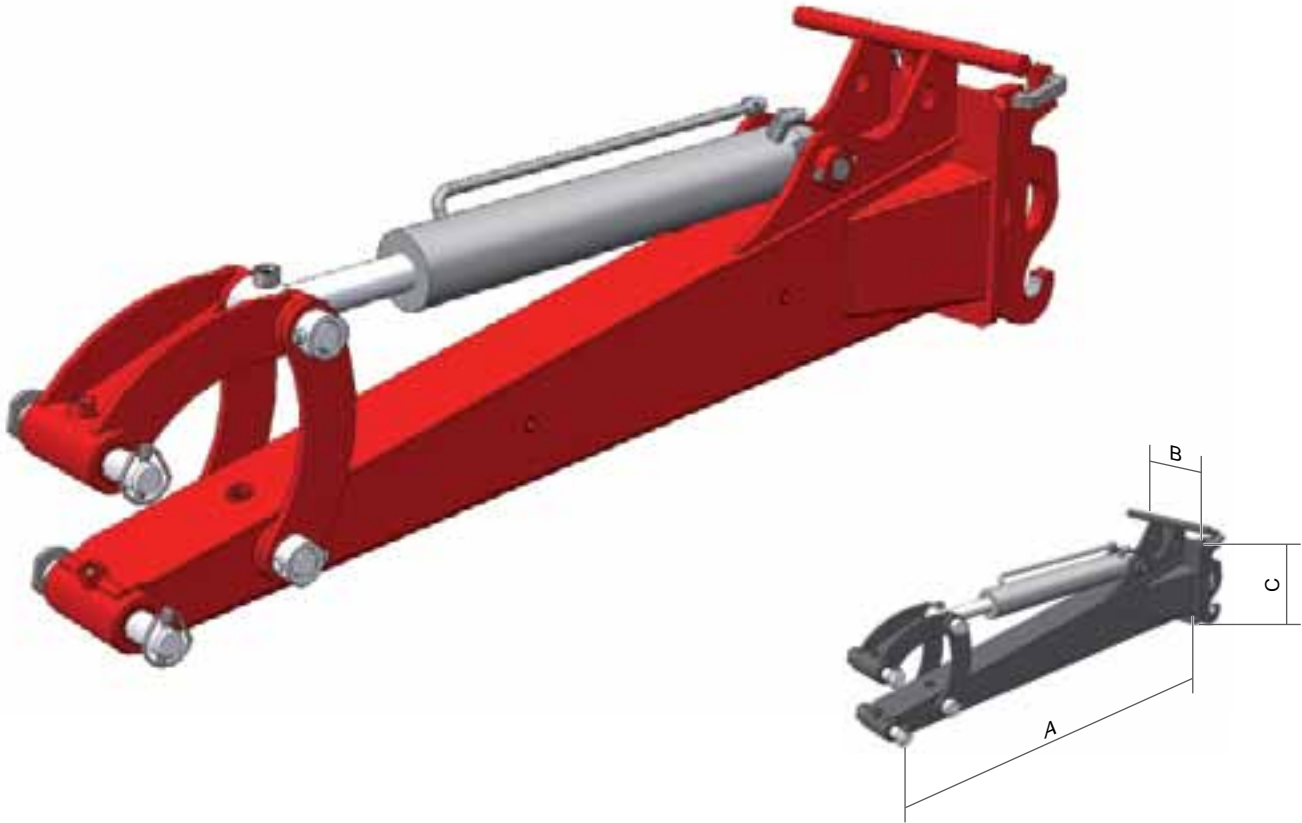

TECHNICAL SPECIFICATION

WEIGHT MACHINE	ton	2,0 - 4,0		4,0 - 7,5	7,5 - 12,0	12,0 - 15,0	12,0 - 15,0
MODEL		BP 100	BP 120	BP 150	BP 180	BP 250	BP 275
A	mm	1000	1200	1500	1800	2500	2750
B	mm	250	250	350	350	650	650
C	mm	300	300	470	470	670	670
WEIGHT		75	85	185	210	470	510
MAX PRESSURE	bar	200	200	200	200	300	300

USE DETAIL



USE DETAIL



SWEeper BUCKET

CANGINIBENNE bucket sweeper, equipped with collection tank suitable for the cleaning of yards and streets. Can be applied water sprinkling-kit with water sprays out- and inside the collection tank. This double sprinklers allow better removal of dust. It is possible apply a side brush for cleaning of curbs and verges. For less wear it is possible apply mixed brushes made of steel / PPL.

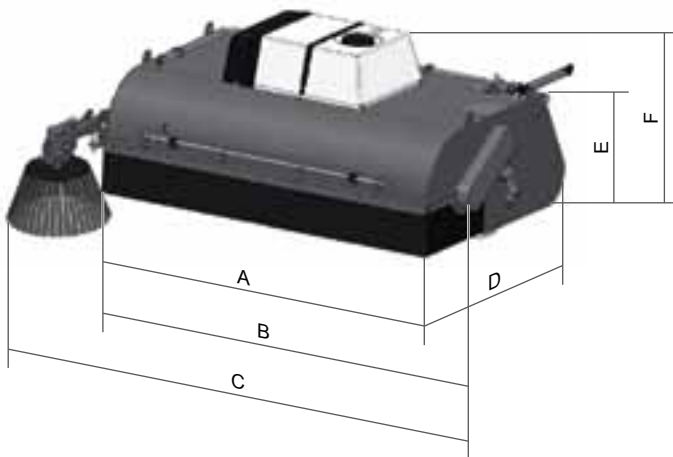
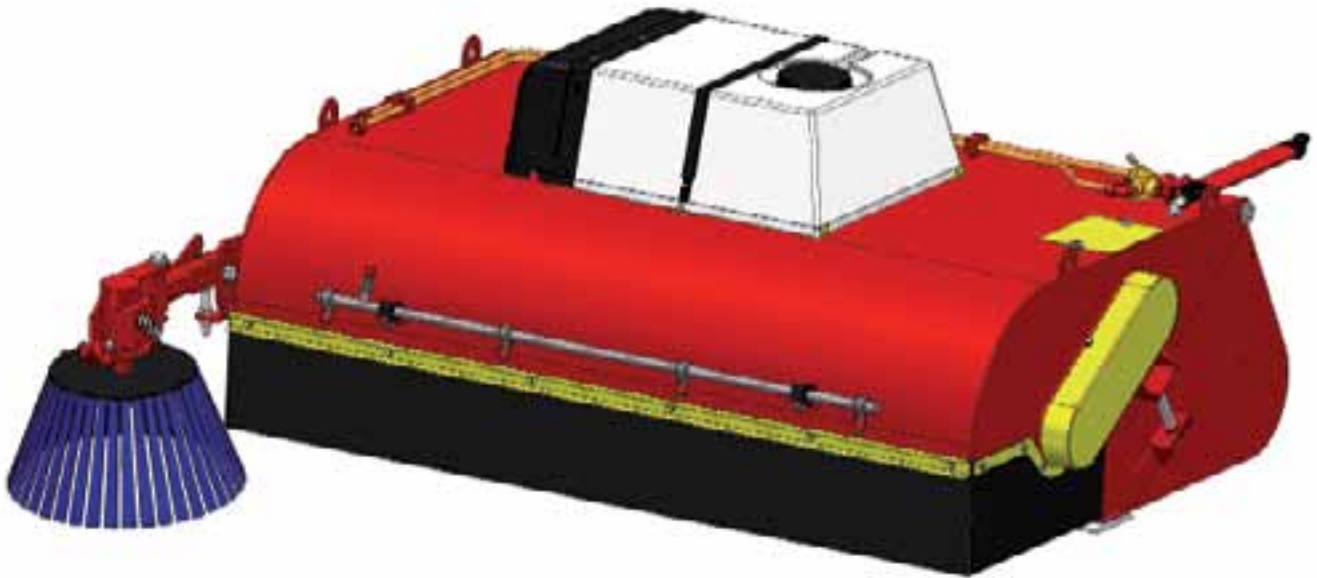

HYDRAULICS CONNECTIONS

hose 1/2 inch. L=2000 mm
quick coupling 1/2 inch. With 1 male and 1 female flatface

SKID ATTACHMENT DETAIL

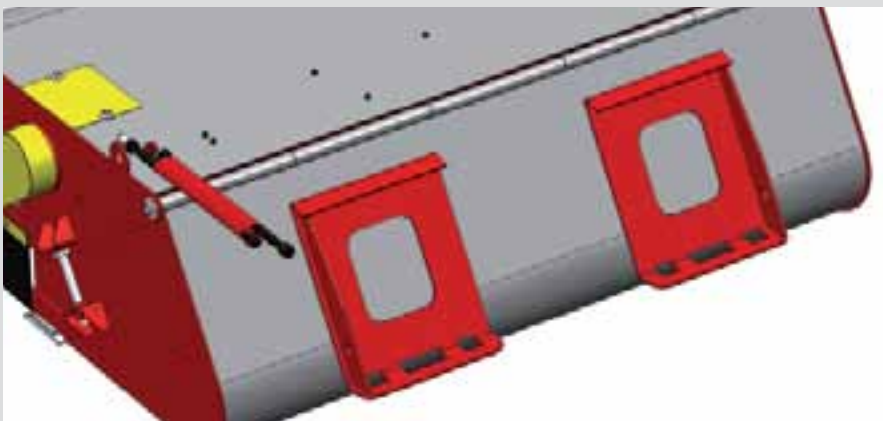

OPTIONAL



ANTISHOCK VALVE

TECHNICAL SPECIFICATION

WEIGHT MACHINE	ton	the matching will be advise according to the technical details of the machine				
MODEL		SPZ 1400	SPZ 1600	SPZ 1800	SPZ 2100	SPZ 2300
A	mm	1400	1600	1800	2100	2300
B	mm	1550	1750	1950	2250	2450
C	mm	1700	1900	2100	2400	2600
D	mm	1390	1390	1390	1390	1390
E	mm	625	625	625	625	625
F	mm	860	860	860	860	860
WEIGHT (without optional)		300	330	360	415	450
BUCKET CAPACITY	lt	380	440	490	570	630
Ø BRUSH	mm	550	550	550	550	550
BRUSH	n°	28 + 2	32 + 2	37 + 2	43 + 2	48 + 2
OIL FLOW	lt/min	50	50	60	70	70
MAX PRESSURE	bar	180	180	180	180	180

OPTIONAL



COMPLETE PRESSURE SPRINKLING KIT LT 75

OPTIONAL



SPRINKLING KIT WITHOUT WATER TANK

OPTIONAL



CABIN WATER TANK LT 75

OPTIONAL



SIDE BRUSH KIT DIAM. 500

OPTIONAL

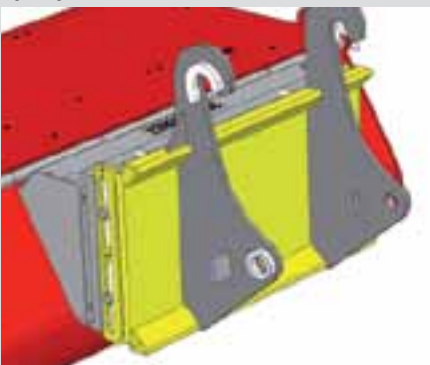

MECHANIC FLOATIN SYSTEM

OPTIONAL

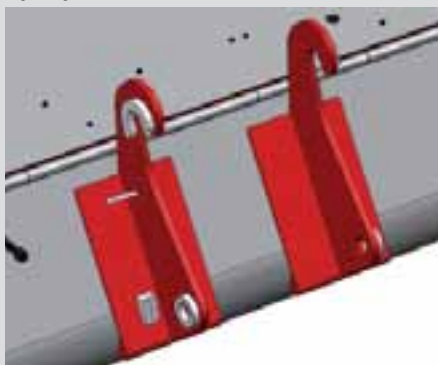

APPLICATION ON ARTICULATED LOADERS, BACKHOE LOADERS, TELESCOPIC

OPTIONAL

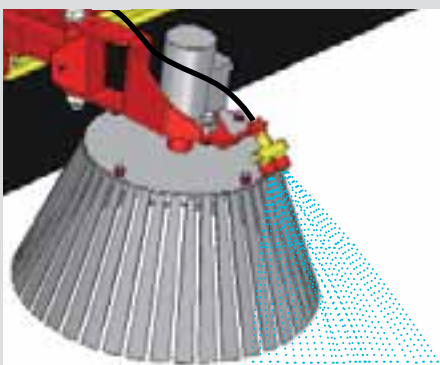

SPRIKLING KIT FOR SIDE BRUSH

OPTIONAL

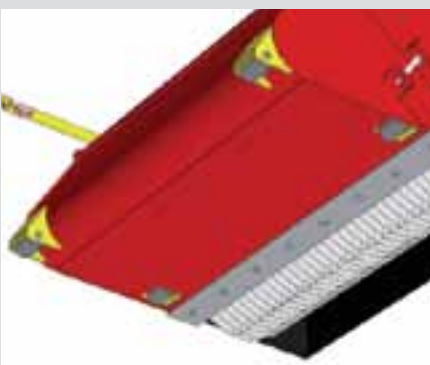

STEEL WHEEL KIT

OPTIONAL

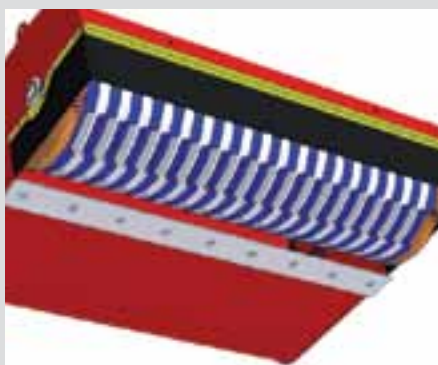

PPL+STEEL BRUSH PRICE FOR EACH BRUSH

ANGLE ROLL SWEEPER

Angle Sweeper without collection bucket is suitable for fast cleaning of yards, streets and snowy roads. It is applicable to, skid loaders, backhoe loaders, telescopic, agricultural tractors and forklifts. Hydraulic angle of $\pm 30^\circ$ right-left, horizontal self leveling $\pm 8^\circ$, supporting and revolving wheels, ZIG-ZAG polypropylene brushes. Options: Water sprinkling kit with or without tank, kit roof tank and brushes in polypropylene+steel.

HYDRAULICS CONNECTIONS

hose 1/2 inch. L=2000 mm
quick coupling 1/2 inch. With 1 male and 1 female flatface

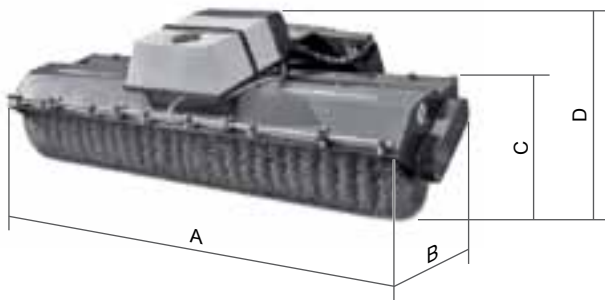

STANDARD EQUIPMENTS

- HORIZONTAL SELFLEVELING $\pm 8^\circ$
- HYDRAULIC ANGLE $\pm 30^\circ$ WITH ELECTRIC VALVE (ONLY FOR HYDRAULIC VERSION)
- SUPPORT TURNING WHEELS
- POLIPROPILENE ZIG-ZAG BRUSH DIAM 550 MM

OPTIONAL



PPL+STEEL BRUSH PRICE FOR EACH BRUSH

OPTIONAL



ANTISHOCK VALVE

TECHNICAL SPECIFICATION

WEIGHT MACHINE	ton	the matching will be advise according to the technical details of the machine									
MODEL		HYDRAULIC					MECHANIC				
		SPI 140	SPI 160	SPI 180	SPI 210	SPI 250	SP 140	SP 160	SP 180	SP 210	SP 250
A	mm	1400	1600	1800	2100	2500	1400	1600	1800	2100	2500
B	mm	1400	1400	1400	1400	1400	1400	1400	1400	1400	1400
C	mm	600	600	600	600	600	600	600	600	600	600
D	mm	800	800	800	800	800	800	800	800	800	800
WEIGHT	kg	300	340	380	420	470	280	320	360	400	450
OIL FLOW	lt	50/70	50/70	50/70	50/70	50/70	50/70	50/70	50/70	50/70	50/70
BRUSH	n°	30	34	38	45	56	30	34	38	45	56
MAX PRESSURE	bar	180	180	180	180	180	180	180	180	180	180

DETAIL



OPTIONAL



COMPLETE PRESSURE SPRINKLING KIT

OPTIONAL



CABIN WATER TANK LT 75

OPTIONAL



APPLICATION ON ARTICULATED LOADERS, BACKHOE LOADERS, TELESCOPIC

OPTIONAL

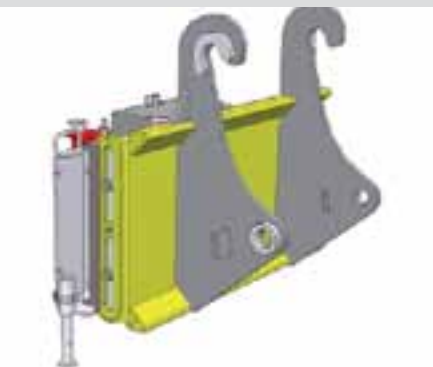

COMPACT MECHANIC FLOATING

OPTIONAL



SPRINKLING KIT WITHOUT WATER TANK

UNIVERSAL SWEEPER

Light and easy to handle, is suitable for cleaning works big and small. Applicable on Skid loaders, miniwheel loaders, backhoe , telescopic, agricultural tractors and forklifts.



OPTIONAL



ON FORK LIFT APPLICATION

OPTIONAL



SKID LOADERS APPLICATION

TECHNICAL SPECIFICATION

ON ARM APPLICATION					
WEIGHT MACHINE	ton	the matching will be advise according to the technical details of the machine			
MODEL		BRU 100	BRU 120	BRU 150	BRU 180
A (width work)	mm	1000	1200	1500	1800
WEIGHT		124	140	170	200
OIL FLOW (min-max)	lt/min	50/90	50/90	50/90	50/90
MAX PRESSURE	bar	200	200	200	200

USE DETAIL



DETAIL



OPTIONAL



APPLICATION ON ARTICULATED LOADERS, BACKHOE LOADERS, TELESCOPIC

OPTIONAL



HYDRAULIC DISCHARGE

MODEL	
BRU 100	
BRU 120	
BRU 150	
BRU 180	

OPTIONAL



SIDE BRUSH

MODEL	
BRU 100	
BRU 120	
BRU 150	
BRU 180	

OPTIONAL



WATER KIT

MODEL	
BRU 100	
BRU 120	
BRU 150	
BRU 180	